



PRODUCT SPECIFICATIONS

NAME: 1~25W 12~90V DC Dimmable Self-Test
Emergency Ballast

ORDER CODE#: SF01ST01.10

TYPE: LED Emergency Ballast
LED Emergency Driver
LED Emergency Conversion Kit

SUB-TYPE: Self-Test Emergency Ballast

UPDATED: 2019-12-18

APPLICABLE FOR: LED Panel Light, Down Light, Ceiling Light, Flood Light, High Bay Light or similar LED system with external driver

FEATURES

- Compact size with dimension L163mm*W40mm*H18mm
- Main and emergency operation
- Auto-run function test every 6 months
- Auto-run duration test every 12 months
- Constant current output
- Overcharge, over discharge protection
- Over temperature protection
- Short circuit protection
- 5-12V Ni-Mh/Ni-Cd High-temperature grade batteries
- Red/Green double-color status indicate LED
- Comply with the latest safety and EMC standards



SPECIFICATIONS

Driver Type	Constant Current
Support Lamps	Downlight/Panel or similar LED system with external driver
Battery Type	Ni-Mh 5-12V / Ni-Cd 1000mAh
Dimmable	Yes
Self-Test Ability	Yes
Warranty	3 Years
Surge-Protection	Yes
LED Indicator	φ5mm Green LED with 300mm Line, 26#

OPERATION SPECIFICATIONS

Output Power	1~25 Watt
Input Voltage	220~240V AC, 50HZ
Output Voltage	12 - 90V DC
Charge Current	0.05C
Illumination Time	1~3 Hour
Recharge Time	24 Hours
Mode Switch Time	<0.5 Sec

Disclaimer: Sanforce© reserves the right to make changes in specifications and/or to discontinue any product at any time without notice or obligation and will not be liable for any consequences resulting from the use of this publication.



WIRING DIAGRAM

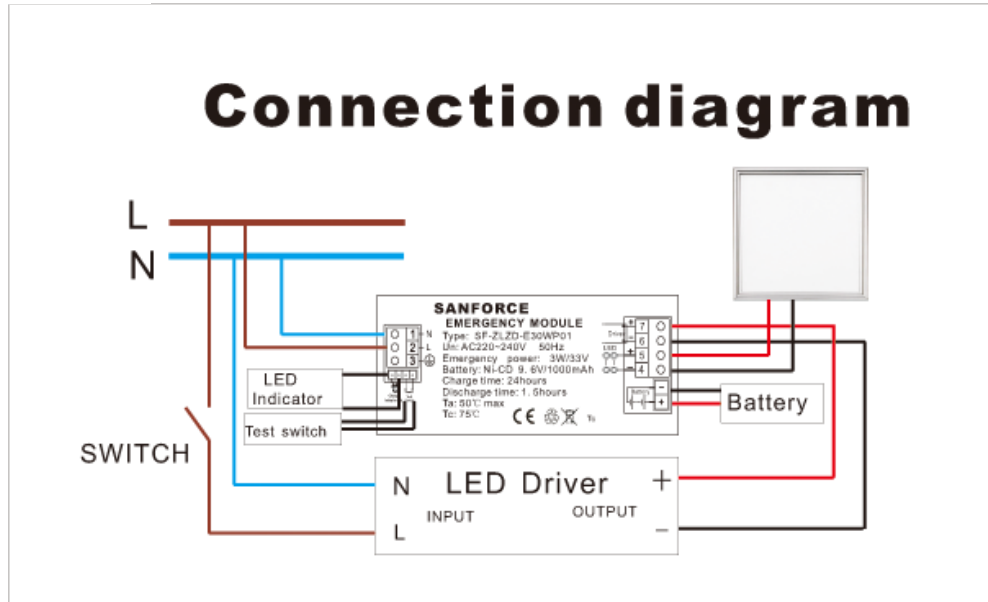

PHYSICAL PROPERTIES

Weight	100 g/pcs
Dimension(mm)	155x40x30
Battery Dimension(mm)	140x50x15
Encasing Dimension(mm)	200x100x53

TEMPERATURE AND RATINGS

Ambient Temperature	-20 to 45°C
Operating Temperature	70°C
IP Rating with Casing	67

SERVICES AND WARRANTY

- Packaging Detail: Standard packaging with export carton or according to requirements.
- Delivery Detail: 7-10 working days for samples, 10-20 days for mass production.
- The warranty period is 3 years or above. According to national standards, a replacement is mandatory after constantly using for 3 years. During the warranty period, it can be replaced with any quality problems (except for man-made factors).
- Requires professional maintenance after emergency power installation, in case any abnormal condition happens, please maintenance in time or inform our company to send professionals to provide technical support.

NOTE

Nickel Metal Hydride (Ni Cd / Ni Mh) Battery Shipping Regulations to comply with IATA provisions for air transporting nickel metal hydride batteries. Please visit the following site to learn more:
<https://www.iata.org/contentassets/b08040a138dc4442a4f066e6fb99fe2a/guidance-document-nickel-metal-hydride-batteries-en-201608.pdf>

Disclaimer: Sanforce© reserves the right to make changes in specifications and/or to discontinue any product at any time without notice or obligation and will not be liable for any consequences resulting from the use of this publication.





No.29, Longfeng Road, Xinsheng, Longgang District, Shenzhen City, China

Tech Support: 0755-89648670, 0755-84293891 Fax: 0755-89648671

Email: info@sanforce-tech.com

www.sanforce-tech.com