



PRODUCT SPECIFICATIONS

NAME: 2~4W 6~60V DC LED Panel Emergency Pack

ORDER CODE#: LCP013C002L, LCP012C003L,
LCP012C004L

TYPE: LED Emergency Ballast
LED Emergency Driver
LED Emergency Conversion Kit

SUB-TYPE: Constant Power Emergency Driver

UPDATED: 2019-12-18

APPLICABLE FOR: LED Downlight/Panel

FEATURES

- Battery integrated with inverter to save space and convenient for installation
- IC controlled dual rate charger for energy savings.
- Battery reverse protection functionality
- Charge indicator and test button.
- Automatically actuated in the event of power cuts
- Offers a good luminous flux to facilitate evacuation in emergency situation.



LCP013C002L: O/p Power=2 W, Illumination Time=3 Hours
 LCP012C003L: O/p Power=3 W, Illumination Time=2 Hours
 LCP012C004L: O/p Power=4 W, Illumination Time=1.5 Hours

SPECIFICATIONS

Driver Type	Constant Power
Support Lamps	Downlight/Panel
Battery Type	Li-ion 18650 2200mAh
Dimmable	Yes
Self-Test Ability	No
Warranty	3 Years
Surge-Protection	Yes
LED Indicator	φ5mm Green LED with 300mm Line, 24#

OPERATION SPECIFICATIONS

Output Power	2~4 Watt
Input Voltage	85-265V AC, 50/60Hz
Output Voltage	6~60V DC
Charge Current	110 mA
Illumination Time	1.5-3 Hours
Recharge Time	24 Hours
Mode Switch Time	<0.5 Sec

Disclaimer: Sanforce© reserves the right to make changes in specifications and/or to discontinue any product at any time without notice or obligation and will not be liable for any consequences resulting from the use of this publication.



WIRING DIAGRAM

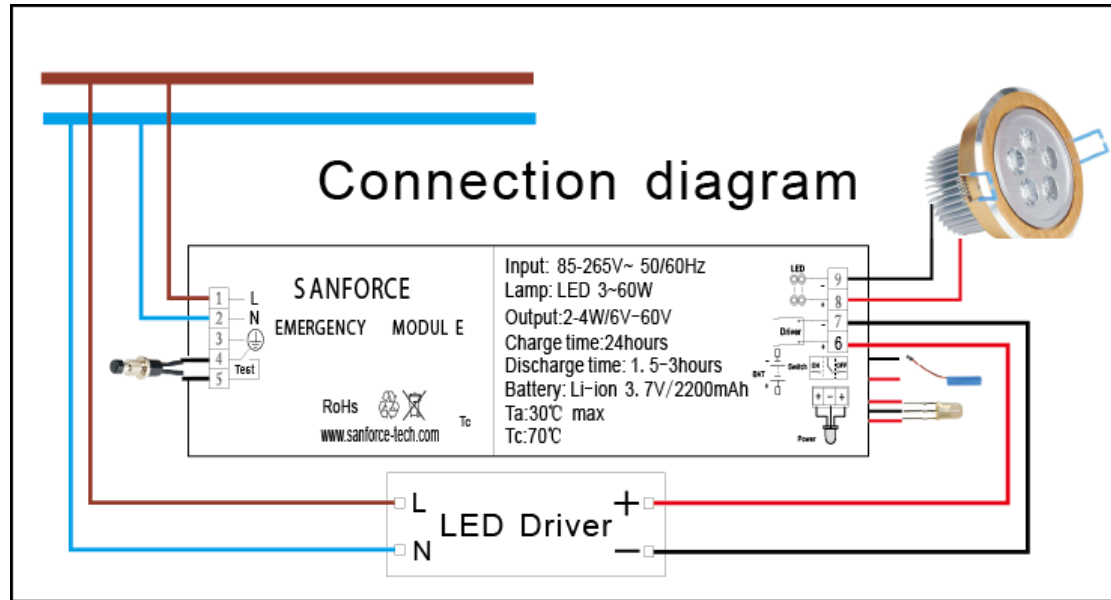

PHYSICAL PROPERTIES

Weight	250 g/pcs
Dimension(mm)	217×40×30
Battery Dimension(mm)	φ18×65
Encasing Dimension(mm)	217×40×30

TEMPERATURE AND RATINGS

Ambient Temperature	-20 to 45°C
Operating Temperature	70°C
IP Rating with Casing	67

SERVICES AND WARRANTY

- Packaging Detail: Standard packaging with export carton or according to requirements.
- Delivery Detail: 7-10 working days for samples, 10-20 days for mass production.
- The warranty period is 3 years or above. According to national standards, a replacement is mandatory after constantly using for 3 years. During the warranty period, it can be replaced with any quality problems (except for man-made factors).
- Requires professional maintenance after emergency power installation, in case any abnormal condition happens, please maintenance in time or inform our company to send professionals to provide technical support.

NOTE

Lithium Battery Shipping Regulations to comply with IATA provisions for air transporting lithium batteries, and for a step by step guidance through the shipping process, please visit <http://www.iata.org/publications/store/Pages/lithium-battery-shipment-guidelines.aspx>.

To view a Classification Flowchart for package marking requirements, please visit <http://www.iata.org/whatwedo/cargo/dgr/Pages/lithium-batteries.aspx>. Scroll to the "Guidance Material" section and click on the provided "Guidance Document" PDF link. The Classification Flowchart will be found on page 5.

Disclaimer: Sanforce© reserves the right to make changes in specifications and/or to discontinue any product at any time without notice or obligation and will not be liable for any consequences resulting from the use of this publication.





No.29, Longfeng Road, Xinsheng, Longgang District, Shenzhen City, China

Tech Support: 0755-89648670, 0755-84293891 Fax: 0755-89648671

Email: info@sanforce-tech.com

www.sanforce-tech.com