



## PRODUCT SPECIFICATIONS

**NAME:** 3W 50--250VDC LED Downlight Emergency

**ORDER CODE#:** SF043CP003P

**TYPE:** LED Emergency Ballast  
LED Emergency Driver  
LED Emergency Conversion Kit

**SUB-TYPE:** Constant Power Emergency Driver

**UPDATED:** 2019-12-18

**APPLICABLE FOR:** LED Downlight/Panel

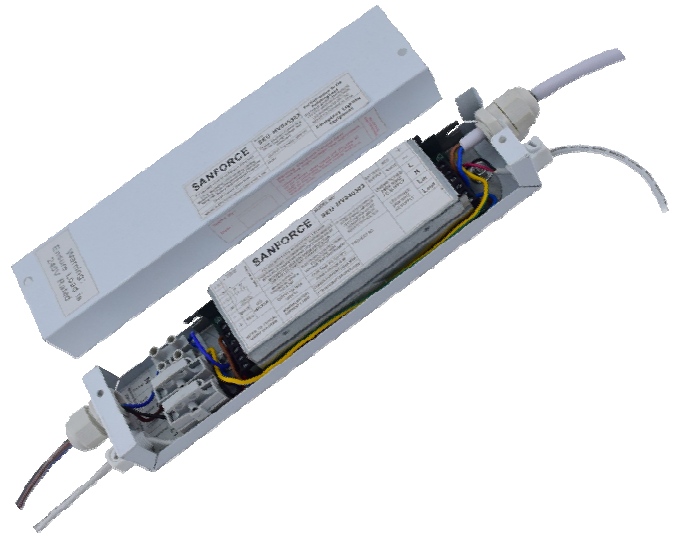

**FEATURES**

- 2-pole changeover relay
- Additional 3rd pole relay
- Deep discharge protection
- Intelligent automatic recharging and converting function
- Constant current battery charger
- 3 hours emergency operation
- Led charge status display
- Inverter with multiple protection functions: charge protection, discharge protection, short circuit protection
- Push-wire terminal blocks for easy wiring installation
- High quality of NI-CD rechargeable battery with 3 years of life.

**SPECIFICATIONS**

<b>Driver Type</b>	Constant Power
<b>Support Lamps</b>	Downlight/Panel
<b>Battery Type</b>	Ni-Cd D4000mAh,4.8V
<b>Dimmable</b>	Yes
<b>Self-Test Ability</b>	No
<b>Warranty</b>	3 Years
<b>Surge-Protection</b>	Yes
<b>LED Indicator</b>	φ5mm Green LED with 300mm Line, 26#

**OPERATION SPECIFICATIONS**

<b>Output Power</b>	3 Watt
<b>Input Voltage</b>	220V-240V, AC 50HZ/60HZ
<b>Output Voltage</b>	50-250V DC
<b>Charge Current</b>	200 mA
<b>Illumination Time</b>	3 Hours
<b>Recharge Time</b>	24 Hours
<b>Mode Switch Time</b>	<0.5 Sec

**Disclaimer:** Sanforce© reserves the right to make changes in specifications and/or to discontinue any product at any time without notice or obligation and will not be liable for any consequences resulting from the use of this publication.



**WIRING DIAGRAM**

# Connection diagram

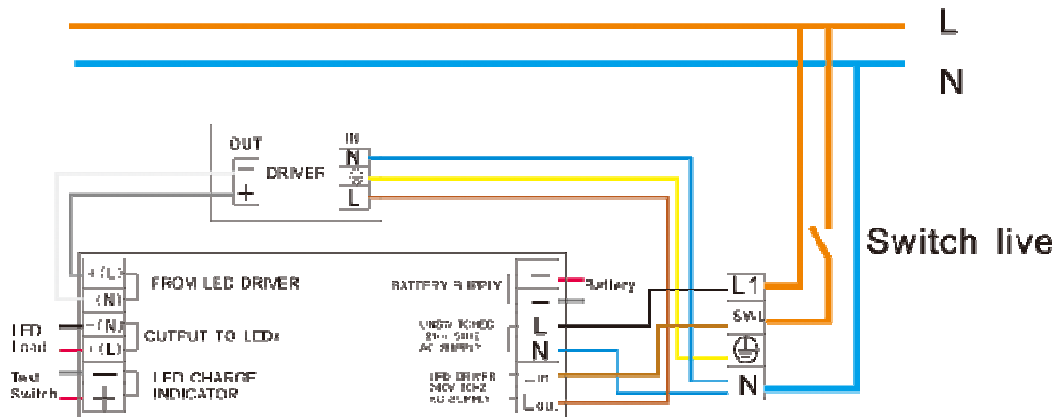
**PHYSICAL PROPERTIES**

**Weight** 800 g/pcs

**Dimension(mm)** 235×52×31

**Battery Dimension(mm)** Φ35×340

**Encasing Dimension(mm)** 235×52×31

**TEMPERATURE AND RATINGS**

**Ambient Temperature** -20 to 45°C

**Operating Temperature** 70°C

**IP Rating with Casing** 67

**SERVICES AND WARRANTY**

- Packaging Detail: Standard packaging with export carton or according to requirements.
- Delivery Detail: 7-10 working days for samples, 10-20 days for mass production.
- The warranty period is 3 years or above. According to national standards, a replacement is mandatory after constantly using for 3 years. During the warranty period, it can be replaced with any quality problems (except for man-made factors).
- Requires professional maintenance after emergency power installation, in case any abnormal condition happen please maintenance in time or inform our company to send professionals to provide technical support.

**NOTE**

Nickel Metal Hydride (Ni Cd) Battery Shipping Regulations to comply with IATA provisions for air transporting nickel metal hydride batteries. Please visit the following site to learn more:  
<https://www.iata.org/contentassets/b08040a138dc4442a4f066e6fb99fe2a/guidance-document-nickel-metal-hydride-batteries-en-201608.pdf>



**Disclaimer:** Sanforce© reserves the right to make changes in specifications and/or to discontinue any product at any time without notice or obligation and will not be liable for any consequences resulting from the use of this publication.



No.29, Longfeng Road, Xinsheng, Longgang District, Shenzhen City, China

Tech Support: 0755-89648670, 0755-84293891 Fax: 0755-89648671

Email: [info@sanforce-tech.com](mailto:info@sanforce-tech.com)

[www.sanforce-tech.com](http://www.sanforce-tech.com)